

KEWTECH

KT1710 Voltage Tester

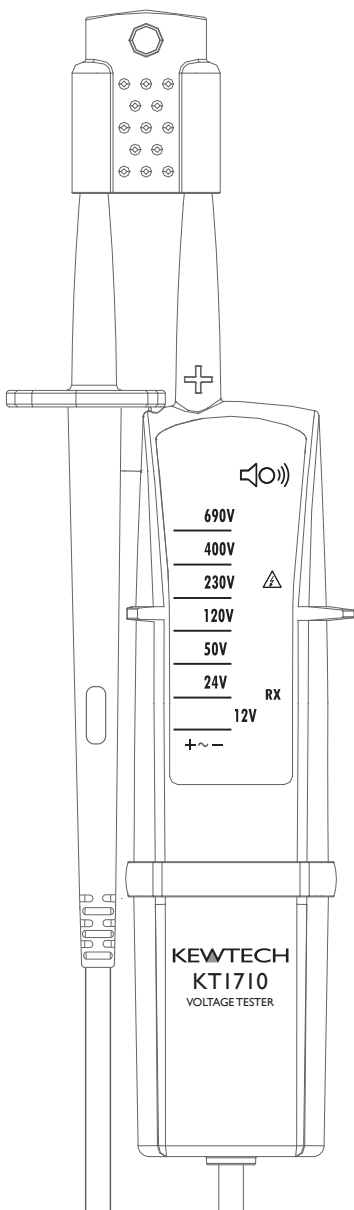





Manual



Contents

1. Introduction / Product Package
2. Safety Measures
3. Danger of electric shock and other dangers
4. Intended Use
5. Tester Information
6. Carrying out Measurements
 - 6.1 Preparation and Safety
 - 6.2 Voltage Test
 - 6.3 Single-pole Phase Test
 - 6.4. Continuity Test
7. Battery Replacement
8. Technical Data
9. Cleaning and storage

References marked on tester or in instruction manual:

-  Warning of a potential danger, comply with instruction manual.
-  Reference. Please pay utmost attention.
-  Caution! Dangerous voltage. Danger of electrical shock.
-  Continuous double or reinforced insulation
-  Conformity symbol, the instrument complies with the valid directives. It complies with the EMV Directive (89/336/EEC), Standard EN 61326-1 are fulfilled. It also complies with the Low Voltage Directive (73/23/EEC), Standard EN61243-3:2014 is fulfilled.
-  Tester complies with the standard (2002/96/EG) WEEE
-  The instruction manual contains information and references, necessary for safe operation and maintenance of the tester.

Prior to using the tester the user is kindly requested to thoroughly read the instruction manual and comply with it in all sections.

-  Failure to read the tester's manual or to comply with the warnings and references contained herein can result in serious bodily injury or tester damage.

The respective accident prevention regulations established by the professional associations are to be strictly enforced at all times

1. Introduction / Product Package

The KT1710 is for voltage and continuity testing.

The tester is constructed according to the latest international safety regulations which ensures safe and reliable working when used in accordance to these instructions.

The KT1710 voltage tester is characterized by the following features:

- Designed to meet international safety standards. EN61243-3:2014
- Measurement Category CAT III 600V / CAT II 690V
- Automatic AC/DC detection
- AC and DC voltage test from 10V up to 690V with LED indication
- Polarity indication
- Single-pole phase test
- Continuity test
- Detects voltage without batteries
- IP54 (IEC60529)

After unpacking, check that the instrument is undamaged.

The product package comprises:

- 1 pc KT1710 tester
- 2 pcs batteries 1.5V, IEC R03 / AAA
- 1 pc operating instructions

2. Safety Measures

-  The tester has been constructed and tested in accordance with the safety regulations for voltage testers and has left the factory in a safe and sound condition.

-  The operating instructions contain information and References required for safe operation and use of the tester. Before using the tester, read the operating instructions carefully and follow them in all respects.

3. Danger of electric shock and other dangers

⚠ To avoid an electric shock, observe the precautions when working with voltages. The tester must not be used with the battery compartment open.

⚠ Before using the tester, ensure that the test lead and device are in perfect working order eg. Look out for broken cables or leaking batteries.

⚠ Hold the tester and accessories by the designated grip areas only, the display elements must not be covered. Never touch the test probes.

⚠ The tester may be used only within the specified measurement ranges and in low-voltage installations up to 690 V.

⚠ The tester may be used only in the measuring circuit category it has been designed for.

⚠ Before and after use, always check that the tester is in perfect working order (e.g. on a known voltage source).

⚠ Do not use the tester if one or more functions fail or if no functionality is indicated.

⚠ It is not permitted to use the tester during rain or precipitation.

⚠ Correct measurement is guaranteed only within a temperature range of -15°C to +55°C at a relative air humidity of less than 85%.

⚠ If the safety of the user cannot be guaranteed, the tester must be secured against unintentional use.

⚠ Safety is no longer guaranteed in the following cases:

- With any obvious damage
- With a broken housing / cracks in housing
- if the tester can no longer perform the required measurements/ tests
- has been stored for too long in unfavorable conditions
- if it has been damaged during transport
- leaking batteries

⚠ The tester complies with all EMC regulations. Nevertheless it can happen in rare cases that electric devices are disturbed by the electrical field of the tester or the tester is disturbed by electrical devices.

⚠ Never use the tester in an explosive environment.

⚠ Tester must be operated by electrically trained users only.

⚠ Operational safety is no longer guaranteed if the tester is modified or altered.

⚠ The tester may be opened by an authorized service technician only.

4. Intended use

The tester may be used only under the conditions and for the purposes for which it was designed. Therefore, observe in particular the safety instructions and the technical data including environmental conditions.

5. Tester information

1. Handle Test Probe, L1 (-)
2. Instrument Test Probe, L2 (+)
3. LED's for voltage indication
4. LED for single-pole (SP)
5. RX (continuity) LED
6. Polarity indication
7. Battery Case
8. Probe-Tip protection
9. Finger guards

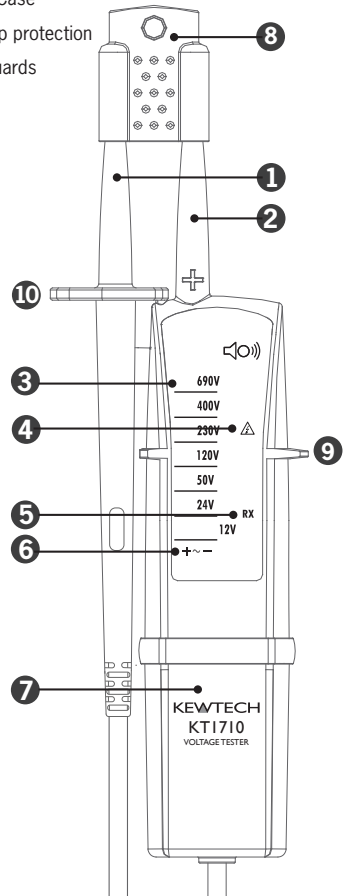

6. Carrying out measurements

6.1 Preparation and Safety

 For any tests the safety references have to be respected as mentioned in Section 2. Prior to any usage, a functional test has to be carried out.

 Test leads and test probes must only be touched behind the finger guards away from the probe tips. Imperative: avoid direct contact of the test probe tips.

Safety advice

- Depending on the internal impedance of the voltage detector there will be a different capability of indicating the presence or absence of operating voltage in case of the presence of interference voltage.
- A voltage detector of relatively low internal impedance, compared to the reference value of 100 k Ω , will not indicate all interference voltages having an original voltage value above the ELV level. When in contact with the parts to be tested, the voltage detector may discharge temporarily the interference voltage to a level below the ELV, but it will be back to the original value when the voltage detector is removed.
- When the indication "voltage present" does not appear, it is highly recommended installing earthing equipment before work.
- A voltage detector of relatively high internal impedance, compared to the reference value of 100 k Ω , may not permit to clearly indicate the absence of operating voltage in case of presence of interference voltage.
- When the indication "voltage present" appears on a part that is expected to be disconnected of the installation, it is highly recommended confirming by another means (e.g. use of an adequate voltage detector, visual check of the disconnecting point of the electric circuit, etc.) that there is no operating voltage on the part to be tested and to conclude that the voltage indicated by the voltage detector is an interference voltage.
- A voltage detector declaring two values of internal impedance has passed a performance test of managing interference voltages and is (within technical limits) able to distinguish operating voltage from interference voltage and has a means to directly or indirectly indicate which type of voltage is present.

Function Test/Self Test

- Insert batteries in tester.
- Test the voltage tester on a known source.
- Connect test probes. An acoustic sound must be audible and the RX (continuity) LED (5) must be off.

6. Carrying out measurements

• For checking of RX touch the probe tips together. An acoustic sound must be audible and the RX (continuity) LED must be on

 The tester must no longer be used if one or several functions fails or if no functional reliability can be detected.

 When the tester is working without batteries RX (continuity) LED (5) will not operate and acoustic sound will be OFF, also the SP (dangerous) LED (4) will not operate.

6.2 Voltage test

- Connect both probes to the object under test.
- The voltage is indicated by LEDs (3).
- Buzzer sounds (only if the tester has batteries inserted) when a threshold voltage of approx. 40VAC/VDC is exceeded. At the same time SP led will be on.
- Voltage polarity is indicated in following manner.
 - AC: + and – 12V LED are on
 - + DC: + 12V LED is on
 - – DC: – 12V LED is on

 When the L2 + (2) probe is the positive potential (negative), the Polarity indication LED indicates "+ DC" ("– DC").

 If using the tester without batteries during a voltage test the buzzer and the single pole LED will not operate.

6.3 Single-pole phase test

 Function of this test may not be fully achieved if the insulation condition/ grounding conditions of user or of the equipment under test aren't good enough. Verification of live-circuit should not be dependent on this Single-pole phase test only, but on the voltage test (See 6.2).

- Hold the tester firmly in your hand. Connect the "L2 +" (2) probe to the object under test. The single-pole LED (4) lights up and buzzer sounds when a voltage of approx. 100V AC or more exists in the object under test. ($Pol \geq 100VAC$).

 This function works only with good working batteries installed.

6.4 Continuity test

 Make sure the object under test is not live.

- Connect both test probes to the object under test. RX (continuity) LED (5) lights up and buzzer sounds continuously to indicate continuity when resistance between tips is less than 500k Ω .

 This function works only with good working batteries.

7. Battery replacement

 Remove the probes from any testing point, when opening the battery case.

 Short the probe tips before any testing to verify battery status.

Voltage level detection is possible without batteries but the buzzer and the single pole LED will not operate.

Follow the procedure below and replace batteries with new ones (type IEC LR03 / AAA 1.5V).

- Unscrew the battery case, with a screwdriver.
- Pull out the battery case and replace the batteries. Insert new batteries according to the engraving on the battery case.
- Re-assemble battery case.

 Confirm that the battery case is properly locked prior to measurements.

8. Technical data

- Voltage range: 12...690V AC (40...70Hz), DC(±)
- LED Nominal voltage:
12/24/50/120/230/400/690V, AC (40...70Hz), DC(±)
- LED tolerances according to EN61243-3
- Response time: < 0.5s at 100% of each nominal voltage
- Peak current: $I_s < 3.5\text{mA}$ (at 400V)
- Measurement Duty: 30s ON (operation time), 240s OFF (recovery time)
- Internal battery consumption: Approx. 80mA
- Single-pole phase test voltage range: 100...690V AC (50/60Hz)
- Continuity test: Detection range 0...500k Ω + 50%
- Battery: 3V (IEC R03 / AAA 1.5V x 2)
- Temperature: -15...55°C operation; -20...70°C storage, No condensation
- Humidity: Max 85% RH
- Altitude up to 2000m
- Overvoltage category: CAT III 600V / CAT II 690V
- Standard EN61243-3:2014
- Pollution degree 2
- Protection: IP 54

9. Cleaning and storage

 Tester does not need any special maintenance if used according to user manual.

 Remove tester from all test points before cleaning.

 Use a lightly damp cloth with neutral detergent for cleaning the instrument. Do not use abrasives or solvents.

 Do not expose the instrument to direct sun light, high temperature and humidity or condensation.

 Remove batteries when the instrument will not be in use for a long period.

KEWTECH

Certificate of Conformity & Warranty Registration

This instrument has been calibrated using equipment which has itself been calibrated to standards traceable to International Standards monitored by BIPM (International Bureau of Weights and Measures)

This certificate guarantees that the product has been fully inspected and conforms to all the relevant published specifications.

Free Two Year Warranty

Kewtech's Two Year Warranty enhances the customers' legal rights/ it covers all manufacturing defects for a two year period but Kewtech reserves the right to exclude abuse or accidental damage.

To register your free guarantee simply go to kewtechcorp.com - the link is on the home page.

Re-calibration Service

Regular re-calibration is recommended for this instrument. Kewtech recommends that with normal use the instrument is calibrated at least once in every 12 month interval.

When the instrument is due for re-calibration return it to the address below marked for the attention of the Calibration Department.

Kewtech Corp Ltd
Shaw Wood Business Park
Shaw Wood Way
Doncaster DN2 5TB
t: 01302 761044